

KU OEM HIGH RANGE PRESSURE SWITCHES

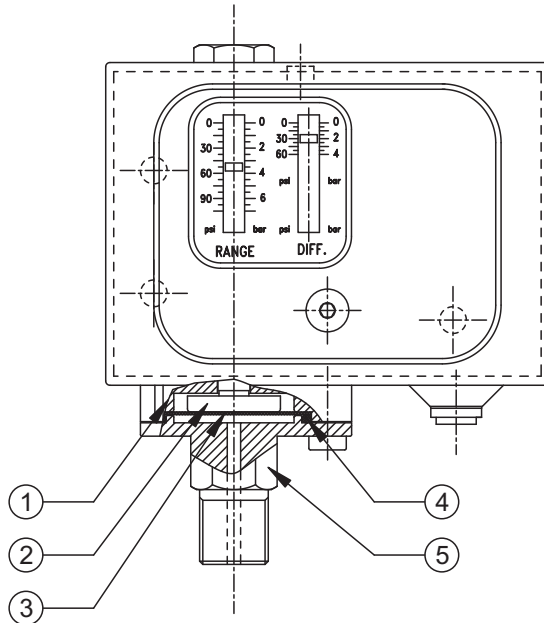

PRESSURE CAPSULE DETAILS



No. Description

1. Disc
2. Plunger
3. Diaphragm (Teflon®)
4. 'O' ring (Teflon®)
5. Pressure Housing (SS316)

Note : *wetted parts* are mentioned in italics.

INSTALLATION DRAWING

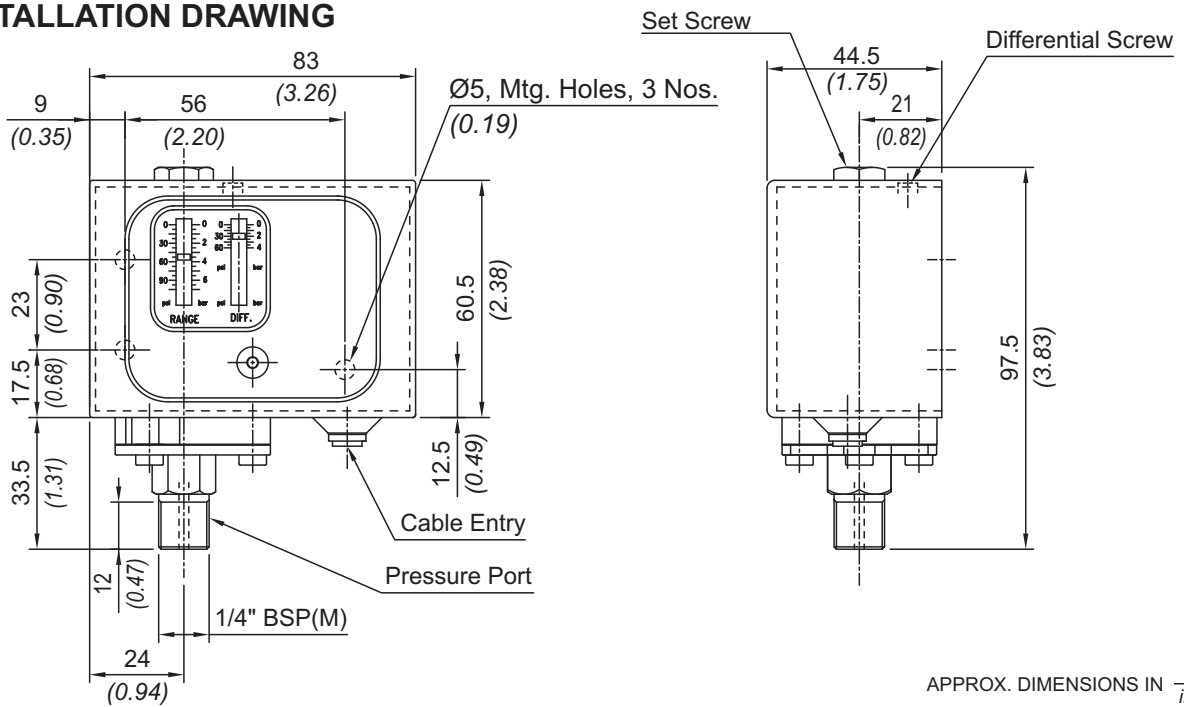

OEM HIGH RANGE PRESSURE SWITCHES

KU

General information:

KU series pressure switches are housed in pressed steel powder coated enclosure and are recommended for panel mounting or indoor service. The repeat accuracy is better than +/-1.5 % FSR, Pressure port is 1/4" BSPM standard.

Features:

- Compact
- SS316 & Teflon as standard wetted parts
- Electrical Rating : 15A, 125/250 VAC
- Pressure port : 1/4" BSPM

Range Selection Table

Model	+ Range Bar (psi)	*Adjustable Differential bar (psi)	Maximum Working Pressure bar (psi)
KU7	0.5 - 7.0 (7.25 - 101.50)	1.2 - 4.0 (17.40 - 58.00)	12 (174.00)
KU15	1.0 - 15.0 (14.5 - 217.5)	2.0 - 8.0 (29.0 - 116.0)	25 (362.5)
KU30	2.0 - 25.0 (29.01 - 362.5)	3.0 - 10.0 (43.5 - 145.0)	35 (507.5)
KU40	5.0 - 32.0 (72.5 - 464.0)	4.0 - 9.0 (58.0 - 130.5)	42 (609.0)

*Minimum Differential increases with Setpoint

HOW TO ORDER KU OEM HIGH RANGE PRESSURE SWITCHES

Please specify model number as per range selection table above.

Graph of Set Point Vs Differential:

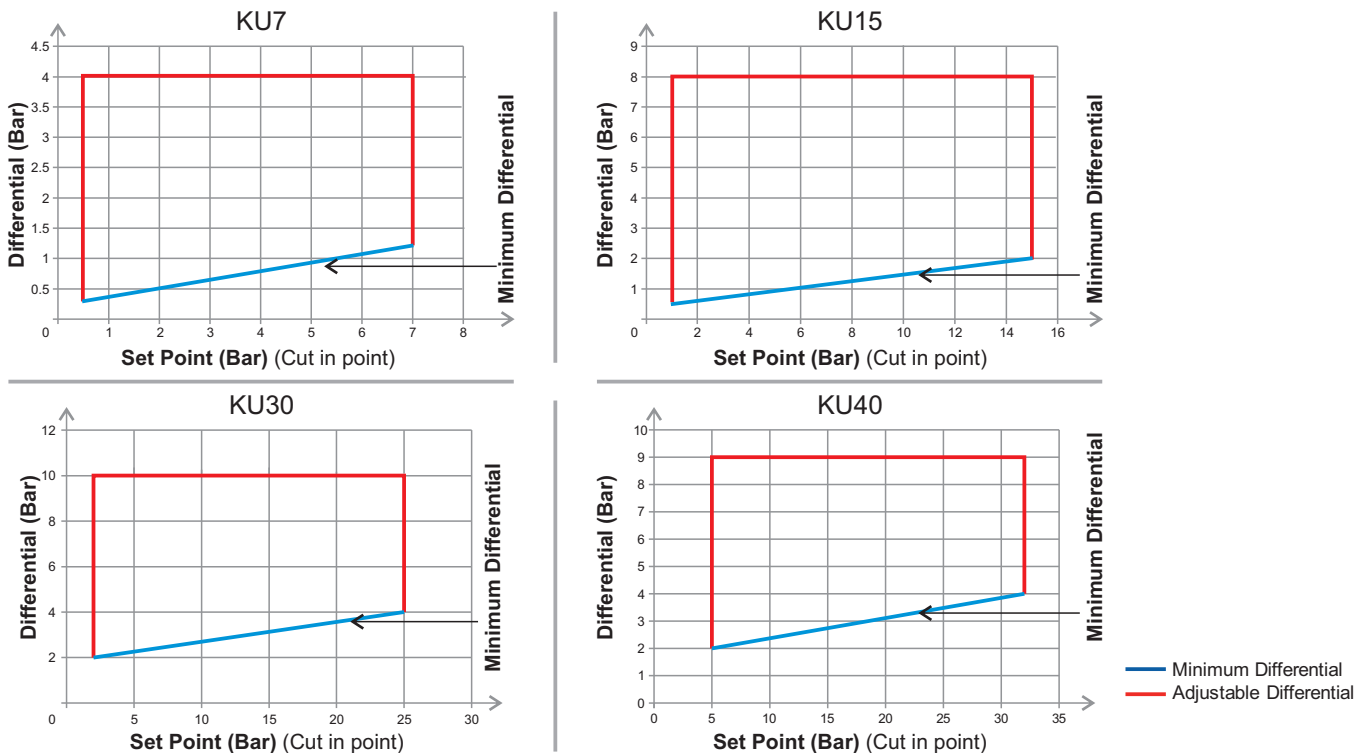

Note : Cut out = Cut in + Differential



Kaustubha Udyog

AN ISO9001:2015 COMPANY

S. No. 36/1/1, Sinhgad Road, Vadgaon Khurd,
Near Lokmat Press, Pune 411 041 INDIA
Tel.: +91-(0) 20-24393577 / 24393877
Telefax : +91-(0) 20-25460486 / 24393577
Email : pressure@vsnl.com

Website : <http://www.orion-instruments.com>